

Model 211-G Ozone Monitor™

EPA Federal Equivalent Method (FEM) for O₃



The new Model 211-G Ozone Monitor uses the proven ultraviolet (UV) absorption method in combination with our patented heated graphite scrubber technology ([U.S. Patent No. 10,295,517](#)) to measure ozone virtually free of interferences. The instrument is ideally suited for measurements of ozone in heavily polluted air where interferences are likely from particulates, mercury, and/or VOCs. The Model 211-G combines the stability of our proven dual beam ozone monitors with our selective scrubber technology to provide accurate ozone measurements in the most polluted air. The enhanced optical path length of 30 cm provides a precision of better than 0.5 ppb for 10-second measurements, and the instrument can output new ozone measurements as often as every 2 seconds. The Model 211-G comes with SD flash card memory as a standard feature. Our [published paper in Atmospheric Measurement Techniques](#) describes the instrument. The Model 211-G Ozone Monitor has been designated by the EPA as a Federal Equivalent Method (FEM) as a **modification** to our Model 211 Scrubberless Ozone Monitor: [EQOA-0514-215](#)

For the most accurate ozone measurements with virtually zero interferences, we recommend our Model 211 Scrubberless Ozone Monitor. However, the Model 211-G offers the ability to measure ozone in heavily polluted urban air with negligible interferences without the use of the nitrous oxide source required by the Model 211. Use of either the Model 211 or Model 211-G in place of conventional ozone monitors has the potential to bring many regions into compliance with the new national ambient air quality standard simply by making a more accurate measurement.

Theory

Ozone monitors based on UV absorbance measure ozone by comparing the transmission of light through a detection cell. Light intensity measurements are made with ozone present (I) and with ozone removed (I_0), and the ozone concentration is calculated using the Beer-Lambert Law. Conventional ozone monitors remove ozone for the I_0 measurement by passing the sample air flow through a solid-phase scrubber (e.g., hopcalite or a series of metal oxide screens). Ideally, the solid-phase scrubber would destroy ozone but pass mercury and other UV-absorbing compounds. In that case, the values of I and I_0 would be reduced by the same amount, and the interfering compounds would not affect the ozone measurement. In practice, however, mercury and aromatic

compounds such as benzene, toluene, xylenes, phenols, etc. either adsorb or react at the solid-phase scrubber surface. As a result, conventional ozone monitors may report erroneously high ozone values by up to a few ppb on highly polluted days and possibly cause a region to be out of compliance with the EPA's ozone standard. The 2B Tech Model 211-G Ozone Monitor greatly reduces interferences from UV-absorbing compounds and mercury by use of a patent-pending heated graphite scrubber composed of graphite tubes heated to a temperature of ~ 130 °C. At the hot graphite surface, ozone reacts to form gas-phase CO and CO₂, the surface being constantly refreshed with underlying carbon. The high temperature prevents significant quantities of VOCs and mercury, which absorbs $\sim 1,000$ times greater than ozone, from adsorbing and being removed from the air stream.

Like our Model 205 Ozone Monitor, the Model 211-G is dual beam, with a measurement of the transmission of UV light through ozone-scrubbed air being made simultaneously with a measurement of UV light passing through unscrubbed sample air, thus increasing the precision and baseline stability of the instrument.

The Model 211-G allows remote instrument operation via RS-232, choice of averaging time (2 s to 1 hr), analog voltage output (0-2.5 V), optional analog current output (4-20 mA), SD flash memory card, and an internal data logger. Our data display and graphing software allows continuous display of data which can be saved for offline analysis.

Schematic Diagram

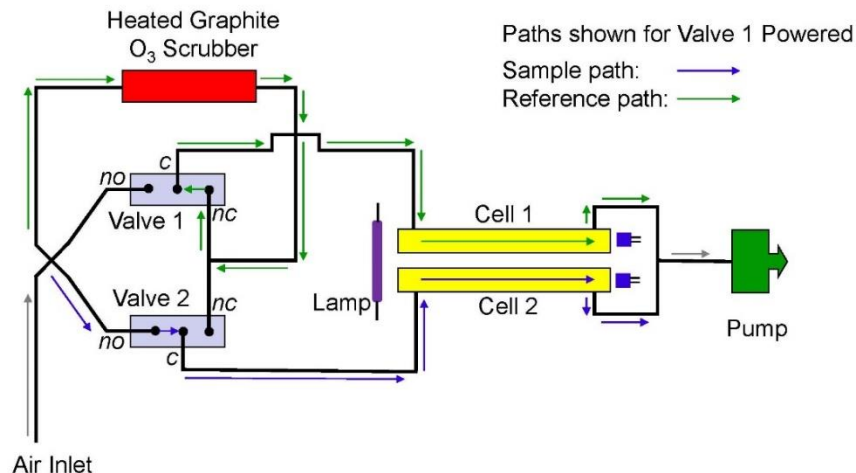

Features

- Measurement of ambient ozone with [patented heated graphite scrubber technology](#) to greatly reduce susceptibility to interferences from other UV-absorbing species such as aromatic VOCs and mercury
- [DewLine™](#) for elimination of water vapor interference, a unique feature of 2B Tech instruments
- Inexpensive, simple, and robust instrument design in a 19" rack mount enclosure
- Internal data logger
- SD flash memory for virtually unlimited portable data storage
- Dual beam, long path (30 cm) optical bench with high precision (< 0.5 ppb)
- NIST-traceable calibration (calibration suggested annually)
- Internal long-life sample pump (15,000 hours)
- EPA Federal Equivalent Method (FEM) for compliance monitoring (modification to [EQOA-0514-215](#))
- Convenient user interface, including remote operation via RS-232 communication

Options

- Battery
- External particle filter
- Lamp heater for outdoor operation in extreme environments
- Bluetooth wireless data transmission
- 4-20 mA analog current output
- External serial-to-USB adapter
- High-altitude upgrade allows operation up to ~25 km (pressure sensor)

Specifications

Measurement Principle	UV Absorbance at 254 nm; Dual Beam
Federal Equivalent Method (FEM)	Yes, 0-500 ppb for 20-30°C: modification to EQOA-0514-215
Ozone Scrubber Technology	Heated graphite scrubber (U.S. Patent No. 10,295,517)
Linear Dynamic Range	0-500 ppb
Resolution	0.1 ppb
Precision (1σ rms noise)	Greater of 0.5 ppb or 1% of reading for 10-s average
Accuracy	Greater of 1.0 ppb or 2% of reading
Limit of Detection (2σ)	1.0 ppb for 10-s average
NIST-Traceable Calibration	Yes
Flow Rate (nominal)	~2 Liter/min
Flow Rate Requirement	>1.2 L/min
Baseline Drift	< 1 ppb/day < 3 ppb/year
Sensitivity Drift	< 0.5%/day < 3%/year
Response Time, 100% of Step Change	20 s for 10-s averaging; 4 s for 2-s measurement
Measurement and Averaging Times	2 s, 10 s, 1 min, 5 min, 1 hr
Internal Data Logger Capacity	16,383 lines (10-s avg. = 1.9 days; 1-min avg = 11 days; 5-min avg = 1.9 mo; 1-hr avg = 1.9 yr)
SD Card Logger Capacity	Minimum 2 GB (> 5-year capacity for 10-s measurement mode)

Ozone Units	ppb, ppm, pphm, $\mu\text{g m}^{-3}$, mg m^{-3}
Pressure Units	mbar, torr
Temperature Units	$^{\circ}\text{C}$, K
T and P Corrected	Yes
Operating Temperature Range	10 to 50 $^{\circ}\text{C}$
Operating Altitude Range	\sim 0-13.5 km (150-1,013 mbar) standard; optional \sim 0-25 km (30-1,013 mbar) with upgraded pressure sensor
Power Requirement; Supplied by Battery or 110/220 VAC Power Pack	11-14 V dc or 120/240 V ac, 1.8 A at 12 V, \sim 22 watt
Size	Rackmount: 17" w x 14.5" d x 5.5" h (43 x 37 x 14 cm)
Weight	13.4 lb (6.1 kg)
Data Outputs	RS232, SD card, LCD, 0-2.5 V Analog, optional 4-20 mA Analog
Data Transfer Baud Rates	2400, 4800, 19200
Output Ranges	User-Defined Scaling Factor in Menu
DewLine™	Yes
Long-Life Pump	Yes, 15,000 hr
Flow Meter	Yes
Options	Battery; External Particle Filter; Bluetooth; External Serial-to-USB Adapter; 4-20 mA Current Output; Lamp Heater; High-Altitude Upgrade, \sim 0-25 km (pressure sensor)

System Includes

- Model 211-G Ozone Monitor
- AC Power Adapter (100-240 VAC to 12 VDC) with Country-Specific Plug
- Zeroing Cartridge
- SD Card and Card Reader
- Operation Manual on USB Stick
- Calibration Data and NIST-Traceable Calibration Certificate
- Instrument Birth Certificate
- One-Year Warranty