



More Precision.

wireSENSOR // Draw-wire displacement sensors





- Robust plastic housing
- Customer-specific designs
- Wire or hybrid potentiometer

MK46 model Output P10/P25

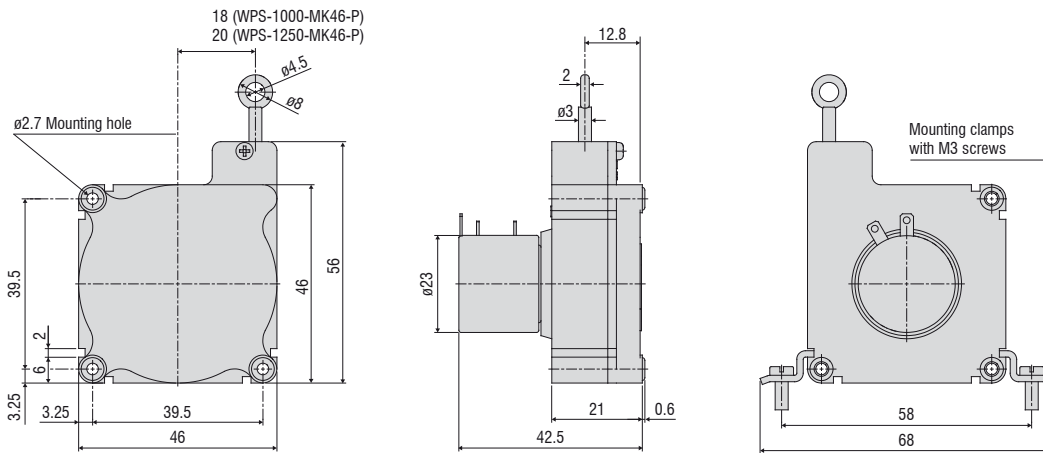

MK46 model Output CR-P25/CR-U10/CR-I10

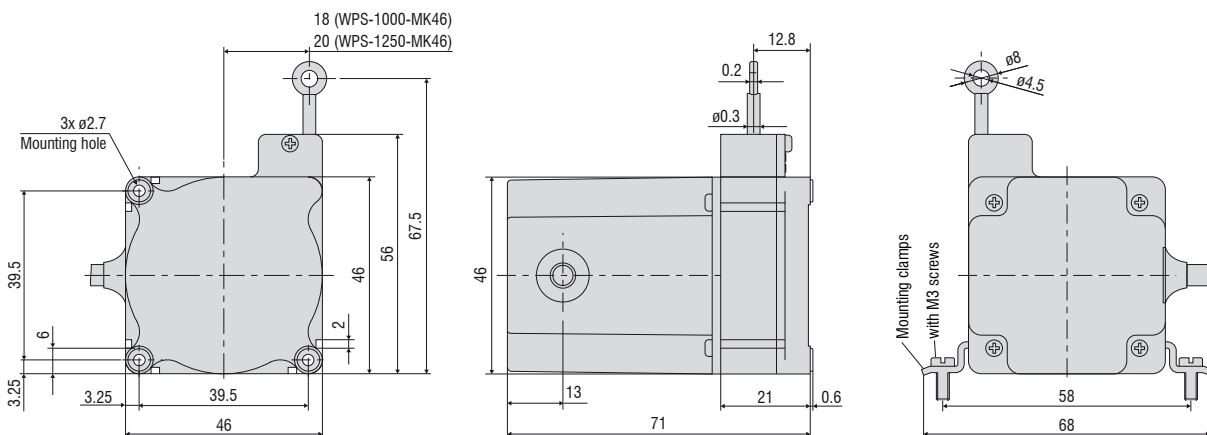

Dimensions in mm, not to scale.

Model		WPS-1000-MK46	WPS-1250-MK46
Measuring range		1000 mm	1250 mm
Analog output		Potentiometer	Potentiometer, current, voltage
Resolution	Wire potentiometer P25	0.3 mm	0.4 mm
	Hybrid potentiometer P10/U10/I10	towards infinity	
Linearity	Wire potentiometer P25	$\leq \pm 2.5$ mm	$\leq \pm 3.12$ mm
	Hybrid potentiometer P10/U10/I10	$\leq \pm 1$ mm	$\leq \pm 1.2$ mm
Sensor element		Wire/hybrid potentiometer	
Wire extension force (max.)		approx. 1.6 N	approx. 1.5 N
Wire retraction force (min.)		approx. 1 N	
Wire acceleration (max.)		approx. 5 g	
Material	Housing	Plastics	
	Measuring wire	Polyamide-coated stainless steel (\varnothing 0.36 mm)	
Wire mounting		Eyelet (\varnothing 4.5 mm)	
Mounting		Mounting holes or mounting grooves on the sensor housing	
Temperature range	Storage	-20 ... +80 °C	
	Operation	-20 ... +80 °C	
Connection	P10/P25	Soldering tags	
	CR-P25/CR-U10/CR-I10	integrated cable, radial, length 1 m	
Shock (DIN EN 60068-2-27)		50 g / 5 ms in 3 axes, 2 directions and 1000 shocks each	
Vibration (DIN EN 60068-2-6)		20 g / 20 ... 2000 Hz in 3 axes and 10 cycles each	
Protection class (DIN EN 60529)		IP20	
Weight		approx. 80 g	

FSO = Full Scale Output

Specifications for analog outputs from page 54 onwards.

Article designation

WPS -	1000 -	MK46 -	P25
			Output type: P25: Potentiometer P10: Potentiometer CR-P25: Potentiometer, integrated cable, radial, 1 m
		MK46 series	
	Measuring range in mm		

WPS -	1250 -	MK46 -	P25
			Output type: P25: Potentiometer P10: Potentiometer CR-P25: Potentiometer, integrated cable, radial, 1 m CR-U10: Voltage, integrated cable, radial, 1 m CR-I10: Current, integrated cable, radial, 1 m
		MK46 series	
	Measuring range in mm		



- Robust plastic housing
- Customer-specific designs
- Incremental encoder

MK46 model

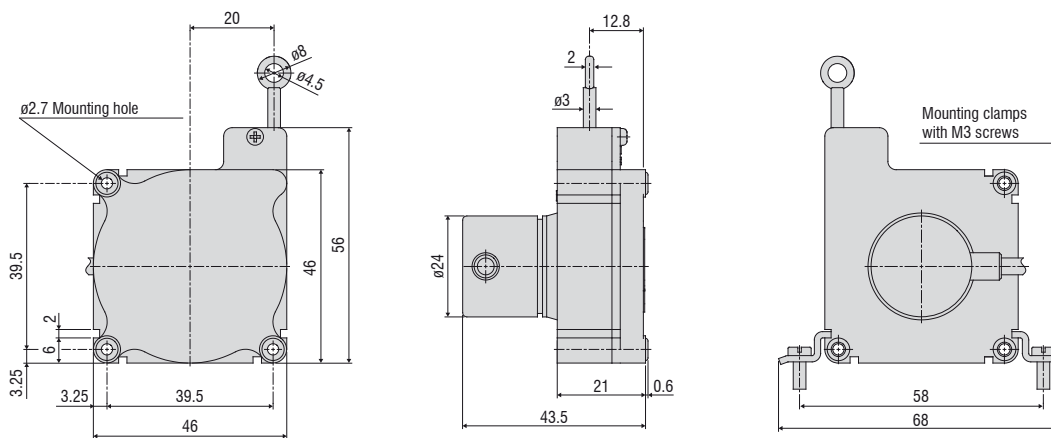

Dimensions in mm, not to scale.

Model		WPS-1250-MK46
Measuring range		1250 mm
Digital output		Encoder: E (5 ... 24 VDC) / Encoder E830 (8 ... 30 VDC)
Resolution		4 pulses/mm
		0.25 mm
Linearity	$\leq \pm 0.05 \% \text{ FSO}$	$\leq \pm 0.625 \text{ mm}$
Sensor element		Incremental encoder
Wire extension force (max.)		approx. 1.5 N
Wire retraction force (min.)		approx. 1 N
Wire acceleration (max.)		approx. 5 g
Material	Housing	Plastics
	Measuring wire	Polyamide-coated stainless steel ($\varnothing 0.36 \text{ mm}$)
Wire mounting		Eyelet ($\varnothing 4.5 \text{ mm}$)
Mounting		Mounting holes or mounting grooves on the sensor housing
Temperature range	Storage	-20 ... +80 °C
	Operation	-20 ... +80 °C
Connection		integrated cable, radial, length 1 m
Shock (DIN EN 60068-2-27)		50 g / 5 ms in 3 axes, 2 directions and 1000 shocks each
Vibration (DIN EN 60068-2-6)		20 g / 20 ... 2000 Hz in 3 axes and 10 cycles each
Protection class (DIN EN 60529)		IP54
Weight		approx. 120 g (incl. cable)

FSO = Full Scale Output

Specifications for digital outputs from page 55 onwards.

Article designation

WPS -	1250 -	MK46 -	E
			Output type: Encoder E (5 ... 24 VDC) Encoder E830 (8 ... 30 VDC)
			MK46 series
			Measuring range in mm

Wire deflection pulleys for external installation

TR1-WDS	Wire deflection pulley, adjustable, for sensors with a wire diameter ≤ 0.45 mm
TR3-WDS	Wire deflection pulley, fixed, for sensors with a wire diameter ≤ 0.45 mm
TR4-WDS	Wire deflection pulley, fixed, for sensors with a wire diameter of 0.8 mm to 1 mm

TR1-WDS

Wire deflection pulley, adjustable, for sensors with a wire diameter ≤ 0.45 mm

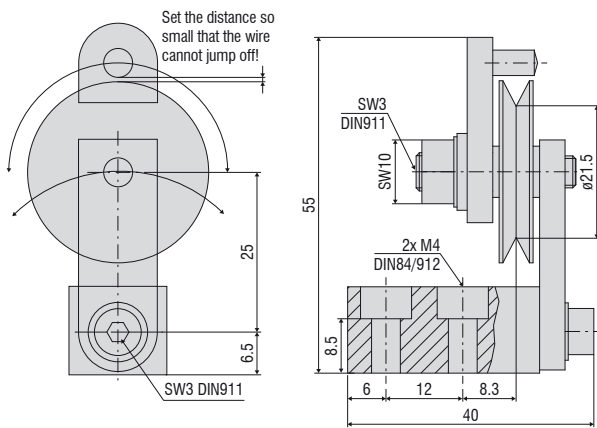

TR3-WDS

Wire deflection pulley, fixed, for sensors with a wire diameter ≤ 0.45 mm

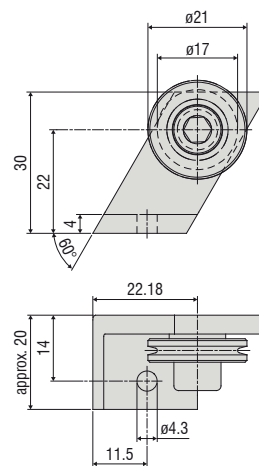

TR4-WDS

Wire deflection pulley, fixed, for sensors with a wire diameter of 0.8 mm to 1 mm

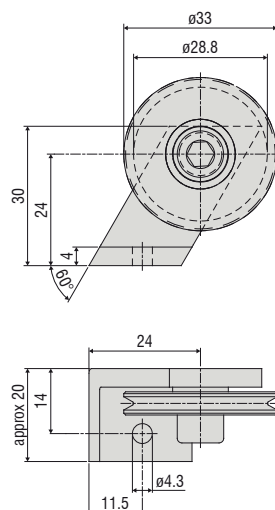

Dimensions in mm, not to scale.

Accessories

WE-xxx-M4	Wire extension with M4 wire connection, x=wire length
WE-xxx-Clip	Wire extension with eyelet, x = wire length
WE-xxx-Clip-WSS	Wire extension with clip and uncoated wire d=0.45 mm
WE-xxx-Ring-PW	Wire extension with plastic ring and para-aramid wire, 1 mm
GK1-WDS	Fork head for M4
MH1-WDS	Magnetic holder for wire attachment
MH2-WDS	Magnetic holder for sensor mounting
MT-60-WDS	Mounting clamps for WDS-P60
FC8	Mating plug for WDS straight, 8-pin
FC8/90	Mating plug, 90° angled for WDS
PC3/8-WDS	Sensor cable, 3 m long
PS2020	Power supply unit 24 V / 2.5 A; input 100-240 VAC, output 24 VDC / 2.5 A; mounting onto symmetrical standard rail 35 mm x 7.5 mm, DIN 50022)
WDS-MP60	Mounting plate for P60 models
PC2/10-WDS-A	Cable for SSI encoder, 2 m long
PC2/10-WDS-E	Cable for incremental encoder, 2 m long
PC10/10-WDS-A	Cable for SSI encoder, 10 m long
PC10/10-WDS-E	Cable for incremental encoder, 10 m long

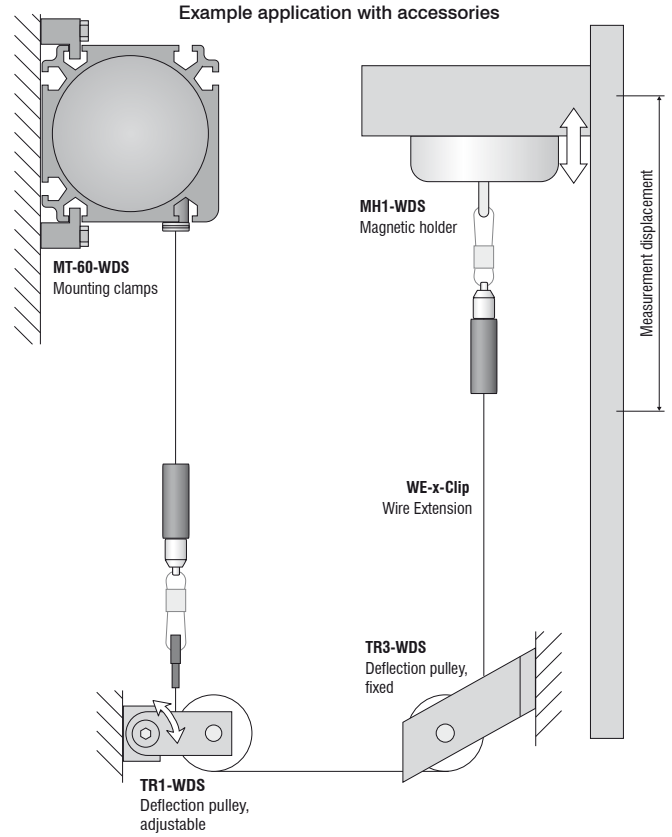

WDS-MP60
Mounting plate for P60 models

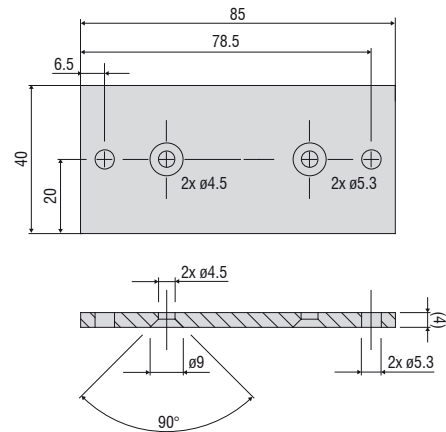

Installation instructions:

Wire attachment: during installation, do not allow at any time the measuring wire to freely return.

Angle of wire outlet: Make sure during installation that the wire outlet is straight (tolerance of $\pm 3^\circ$). Exceeding this tolerance leads to increased wear of the wire material and on the wire outlet.

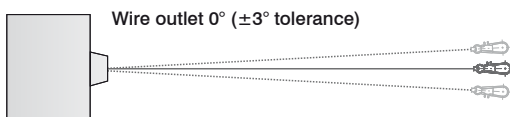

WE-xxxx-M4

Wire extension with M4 wire connection, x=wire length

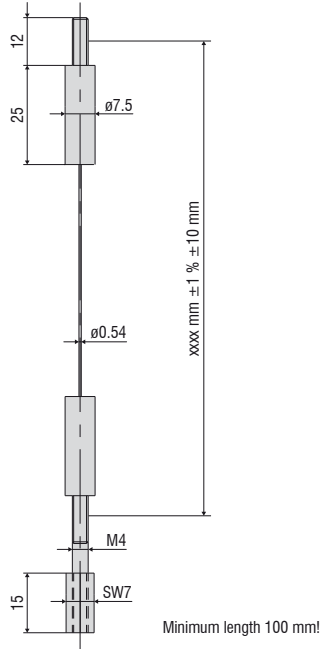

WE-xxxx-Clip

Wire extension with eyelet, x = wire length

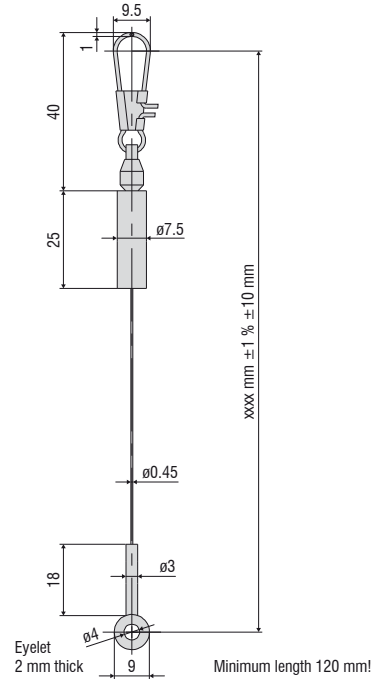

MH1-WDS

Magnetic holder for wire attachment

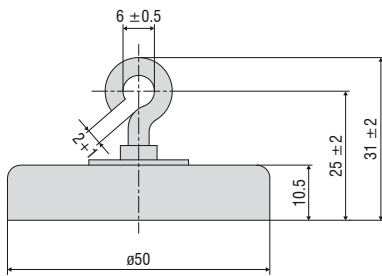

MH2-WDS

Magnetic holder for sensor mounting

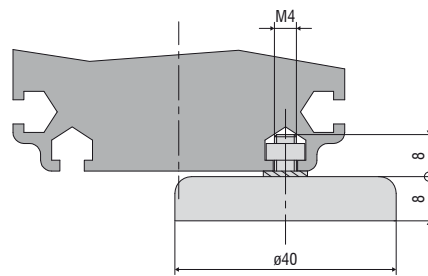

GK1-WDS

Fork head for M4

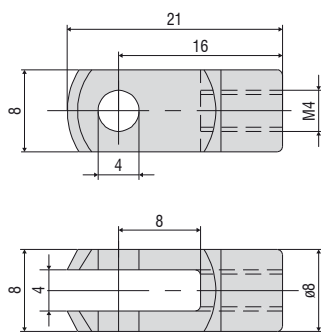

MT-60-WDS

Mounting clamps for WDS-P60

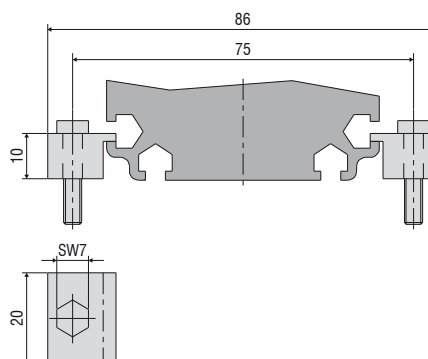

Output	Connector M16 -SA / -SR	Integrated cable -CA / -CR	Open contacts
--------	----------------------------	-------------------------------	---------------

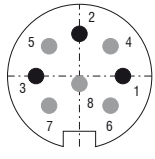
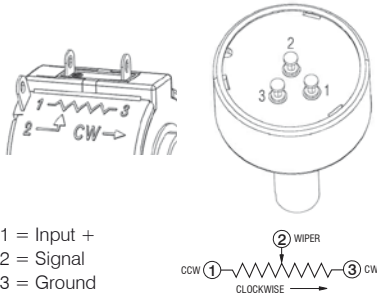
Potentiometer output (P)		 <p>Sensor side</p> <p>1 = Input + 2 = Ground 3 = Signal</p>	<p>White = Input + Brown = Ground Green = Signal</p>	 <p>1 = Input + 2 = Signal 3 = Ground</p>
Input voltage	max. 32 VDC with 1 kOhm / max. 1 W			
Resistance	1 kOhm ± 10 % (resistance divider)			
Temperature coefficient	±0.0025 % FSO/°C			

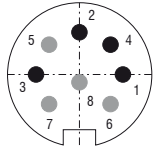
Voltage output (U)		 <p>Sensor side</p> <p>1 = Power supply 2 = Ground 3 = Signal 4 = Ground</p>	<p>White = Supply Brown = Ground Green = Signal Yellow = Ground</p>
Supply voltage	14 ... 27 VDC (non-stabilized)		
Current consumption	max. 30 mA		
Output voltage	0 ... 10 VDC Option 0 ... 5 / ±5 V		
Load resistance	>5 kOhm		
Output noise	0.5 mV _{eff}		
Temperature coefficient	±0.005 % FSO/°C		
Electromagnetic compatibility (EMC)	EN 61000-6-4 EN 61000-6-2		
Adjustment range (if supported by the model)			
Zero	±20 % FSO		
Sensitivity	±20 %		

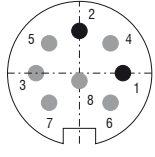
Current output (I)		 <p>Sensor side</p> <p>1 = Power supply 2 = Ground</p>	<p>White = Supply Brown = Ground</p>
Supply voltage	14 ... 27 VDC (non-stabilized)		
Current consumption	max. 35 mA		
Output current	4 ... 20 mA		
Load	<600 Ohm		
Output noise	<1.6 μA _{eff}		
Temperature coefficient	±0.01 % FSO/°C		
Electromagnetic compatibility (EMC)	EN 61000-6-4 EN 61000-6-2		
Adjustment range (if supported by the model)			
Zero	±18 % FSO		
Sensitivity	±15 %		

Output signals

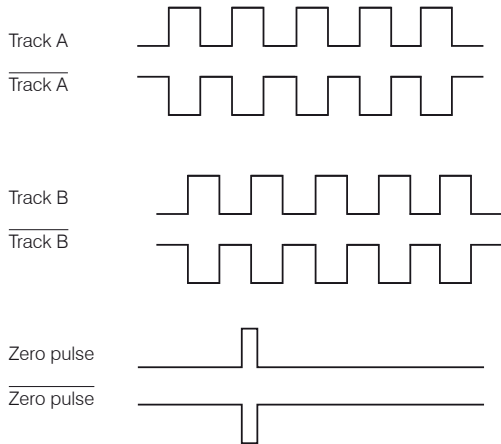

TTL Output	Line driver (5 VDC)	
High level	$\geq 2.5\text{ V}$	(with $I = -20\text{ mA}$)
Low level	$\leq 0.5\text{ V}$	(with $I = 20\text{ mA}$)
Load High	$\leq 20\text{ mA}$	
Tracks	A, \bar{A} , B, \bar{B} , 0	

Output TTL01/ TTL02	NPN (5 VDC $\pm 5\%$)	
High level	$> 4.5\text{ V}$	
Low level	$< 1.0\text{ V}$	
Load High	$\leq 3\text{ mA}$	
Tracks (TTL01)	A, B, 0	
Tracks (TTL02)	A, \bar{A} , B, \bar{B} , 0	

Output HTL	Push-pull (10 ... 30 VDC)	
High level	$\geq V+ - 3\text{ V}$	(with $I = -20\text{ mA}$)
Low level	$\leq 1.5\text{ V}$	(with $I = 20\text{ mA}$)
Load High	$\leq 40\text{ mA}$	
Tracks	A, \bar{A} , B, \bar{B} , 0	

Output E	Push-pull (5 VDC)	
High level	$\geq V+ - 2.5\text{ V}$	
Low level	$\leq 0.5\text{ V}$	
Load High	$\leq 50\text{ mA}$	
Tracks	A, B, 0	

Output E830	Push-pull (8 ... 30 VDC)	
High level	$\geq V+ - 3\text{ V}$	
Low level	$\leq 2.5\text{ V}$	
Load High	$\leq 50\text{ mA}$	
Tracks	A, B, 0	

Pin assignment TTL, HTL

Connector	Cable color	Assignment
Pin 1	Pink	Track B inv.
Pin 2	Blue	V+ Sense
Pin 3	Red	Track N (zero pulse)
Pin 4	Black	Track N inv. (zero pulse inv.)
Pin 5	Brown	Track A
Pin 6	Green	Track inv.
Pin 7	-	-
Pin 8	Gray	Track B
Pin 9	-	-
Pin 10	White-green	GND
Pin 11	White	GND Sense
Pin 12	Brown-green	V+

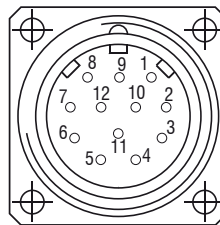

V+ Sense and GND Sense are directly connected to V+ or GND. Recommendation: Use twisted-pair cables (e.g. A/A inv.) from a cable length of 10 m.

Pin assignment E, E830

Cable color	Assignment
White	0V
Brown	V+
Green	A
-	\bar{A}
Yellow	B
-	\bar{B}
Gray	0

Pin assignment TTL01

Cable color	Assignment
Brown	0V
Gray	V+
White	A
Green	B
Yellow	0

Pin assignment TTL02

Cable color	Assignment
Red	V+
Black	0V
Brown	A
Black	\bar{A}
Orange	B
Black	\bar{B}
Yellow	0
Black	n. c.

Sensors and Systems from Micro-Epsilon

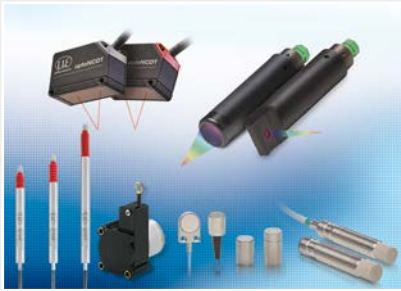

Sensors and systems for displacement, distance and position



Sensors and measurement devices for non-contact temperature measurement



Measuring and inspection systems for metal strips, plastics and rubber



Optical micrometers and fiber optics, measuring and test amplifiers



Color recognition sensors, LED analyzers and inline color spectrometers



3D measurement technology for dimensional testing and surface inspection